

Engineering Drawings

Engineering Drawings Tutorial Dec 2009

Click here to start

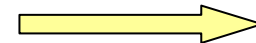

NEXT

Engineering Drawings

- They are made of:
 - *Mechanical Drawings* reflecting the original aircraft configuration at delivery for the customer fleet. They do not reflect the changes made to the aircraft post delivery by SB or Customer Originated Change (COC)
 - *Tool Equipment Drawings* as identified in the TEI/TEM index
 - *Repair Drawings*
 - The mechanical drawing set is divided into aircraft families:
 - Wide body (starting with letter A and B):A300/A310/A300-600
 - Single Aisle (starting with letter D and E):A318/A319/A320/A321
 - Long Range (starting with letter F and G):A330/A340
- A Mechanical drawing set is made of 3 documents, all bearing the same drawing number
 - The picture, showing the graphic data
 - The schedule (or detail Parts List)
 - The Parts Usage that provides for each part number its next higher assembly (NHA) and corresponding aircraft effectivities
- Engineering Drawings Access
 - The access filter for engineering drawings is the production aircraft effectivity
 - Should the drawing you require not be originally validated on your aircraft, your access to such drawing will be denied

NEXT

Engineering Drawings

- Workstation Configuration
 - For efficient use of Engineering Drawings some configuration is mandatory
 - Standard mandatory settings required by AirbusWorld
 - Screen resolution 1024x768
 - TIFF viewer for graphic display (ISOVIEW recommended or PRIZM)
 - Acrobat reader 6.0 or more for Parts List and Parts Usage
- Engineering Drawings Functionalities
 - Capabilities to search with a partial number followed by “*”
 - “Top – Down” navigation by using Parts List
 - “Bottom - Up” navigation by using Parts Usage
 - Convenient print function allowing to print drawing set (graphic,Parts List and Parts Usage)
 - Download of full drawing set package
 - RFI (Request For Information)
 - DNI (Drawing Numerical Index)

NEXT



Engineering Drawings

- During this guided tour you will become familiar with:
 - Tutorial part 1
 - The interface layout
 - Direct access/open searches
 - Top – Down navigation using Parts List
 - Tutorial part 2
 - Bottom - Up navigation using Parts Usage
 - Important functions such as:
 - Full Screen
 - DNI
 - RFI
 - Print
 - Download

[NEXT](#)

Engineering Drawings

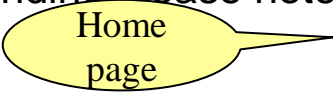
PLEASE READ CAREFULLY INFORMATION BELOW

- The following slides give you an overview of the navigation through Engineering Drawings
 - For a better understanding please note that you will get two kinds of “callout”
 - The yellow one  which provides information and tips
 - The blue one  which requests that you click with your mouse on a specific zone or specific link
 - At any time, links available are shown with your mouse changing from “**arrow**” to a “**hand**”.In such case click within the area.
 - If you want to quit ,depress “**ESCAPE**” at any time
 - At any time “**Restart**” brings you back to the Engineering Drawings home page.
 - Each layout presented through this demo is an exact copy of the “on line service”. If your workstation complies with the AirbusWorld requirements you should be able to recreate the same navigation on your PC.

[NEXT](#)

Engineering Drawings

- Access on AirbusWorld portal
 - The service is accessible on AirbusWorld from:
 - The Maintenance and Engineering Community – Perform Engineering activities process - Follow-up Technical Information page
 - The On-line service map
 - My on-line services

The image displays two screenshots of the AirbusWorld portal interface. The top screenshot shows the 'Maintenance & Engineering community map' page. The 'Perform Engineering Activities' section is highlighted with a red circle, and the 'Follow-up technical information' link is also circled in red. The bottom screenshot shows the 'Engineering drawings' page, where the 'Engineering Drawings' link in the left sidebar is circled in red. Both screenshots show the navigation menu at the top, including 'Home', 'Customization & Delivery', 'On-line service map', 'Corporate jet pilot', and 'Maintenance & Engineering'.

NEXT

Engineering Drawings

- Access on AirbusWorld portal
 - A service card describing Engineering Drawings service is accessible on AirbusWorld from “On-line service map”

The image displays a screenshot of the AirbusWorld portal interface. At the top, the navigation bar includes 'Home', 'Customization & Delivery', 'On-line service map' (highlighted with a red circle), 'Corporate jet pilot', and 'Maintenance & Engineering'. Below the navigation bar, the 'On-line service map' section is visible, listing various services such as Airbus Suppliers, Certification, Leasing, and Maintenance & Engineering. A red arrow points from the 'On-line service map' section to a detailed 'Engineering Drawings' service card. The service card includes a 'Service description' section with the following text:

Service description
Airbus provides to customer services on operations with certain drawing categories, available online exclusively. This connection to AirbusWorld web portal allows users to address requirements for online services Engineering Drawings.

Mechanical drawings (A30):
Basic Drawing set - mechanical part
The mechanical drawing set includes Airbus CAD (Installation, assembly and Detail part drawings) for structure and cabin architecture, offered to the customer aircraft on fleet. Scope is limited to the "as designed aircraft" in its original configuration (at first aircraft delivery, with respect to the last drawing release).

Individual drawings on demand:
To cover additional requirements, the 3D/2D Drawing service, is a complementary service, for drawings which are not in the scope of the basic drawing set (post-delivery configuration, fit associated drawings, repair drawings, extra specific drawings or specific forms).

Tool Equipment Drawings (E10):
Provides access to the Tool Drawings as identified in the 762/760 index.
Drawings not listed in the TTE are not available in this application, not granted to BRG.

Repair drawings (R1-drawings):
An on-line set of the mechanical drawings must be ordered (used in accordance with an Airbus approved document (DRG, BR, RA4)). They can be ordered from the Repair Drawings module thru the dedicated order form, or by mail to the Airbus Drawing service at: drawing.serv@airbus.com

Drawing categories below are not managed in the online services:

- Airbus Vendor drawings
- Electrical drawings
- CAD/CAM drawings

On the right side of the portal, there is a 'What's new on Airbus World' section with news items from June 2009, April 2009, and March 2009. Below that, there are contact details for 'Airbus Technical AOG Center' and 'Airbus Spares AOG Center'. At the bottom right, there is a 'Help Desk' section with support contact information. A red arrow also points from the 'Engineering Drawings' service card to the 'Airbus Spares AOG Center' contact information.

NEXT

Engineering Drawings V5 Startup - Windows Internet Explorer fourni par Sopra Group

Fichier Edition Affichage Favoris Outils ?

Précédente → Favoris

Adresse <https://services.airbus.com/ui00/consult/html/> OK

Airbus Online Services - Engineering Drawings

Please, select a drawing family

<u>Mechanical Drawings</u>
<u>Tool Equipment Drawings</u>
<u>Repair Drawings</u>

This page provides access to 3 different types of drawings

Click "Mechanical Drawings"

For drawing set related queries, and in case of negative search result, please contact :
Daniele KIRK phone : 00 33 561 93 38 82, e-mail : daniele.kirk@airbus.com
or
Brigitte FRANCHINI phone : 00 33 561 93 38 52, e-mail : brigitte.franchini@airbus.com
For all other Airbus Online Services access queries please contact the Airbus Help desk

Terminé Internet

https://services.airbus.com - Engineering Drawings V5 - Windows Internet Explorer fourni par Sopra Group

Mechanical Drawings

Robin ANDERSON
AIRBUS
All MSN

Drawing Number
(D53210000, D5321*)

Search Clear

Advanced Search

Introduction to the Engineering Drawing Service

Drawing Set User Guide - Mechanical Drawings

Restart RFI Help

Terminal Internet

Both documents provide very useful information

Click anywhere to go to the next slide

Mechanical drawings home page

To search for a drawing insert the drawing number always starting with a letter and at least 4 digits.

The « * » is used as a wild character

- Wide body (starting with aircraft letter A and B): A300/A310/A300-600
- Single aisle (starting with letter D and E): A318/A319/A320/A321
- Long range (starting with letter F and G): A330/A340

Mechanical Drawings

Robin ANDERSON
AIRBUS
All MSN

Drawing Number
(D53210000, D5321*)

Looking for a structure drawing reference A538107*

- [Introduction to the Engineering Drawing Service](#)
- [Drawing Set User Guide - Mechanical Drawings](#)

Click "Search"

Mechanical Drawings

Robin ANDERSON
AIRBUS
All MSN

Drawing Number: A538107*
(D53210000, D5321*)

Search Clear

Advanced Search

Other Functions

90 items found [Drawing Pictures]

Remark: Aircraft validity is only checked when you select a reference among this list.

VERY Important note

		Add to batch
A53810700	JOINT ASSY	<input type="checkbox"/>
A53810701	STRUCTURE ASSY-15/21	<input type="checkbox"/>
001 B00		
A53810702	COMPONENTS ASSY-	<input type="checkbox"/>
001 N00		
A53810703	JOINT ASSY-SECT15/21	<input type="checkbox"/>
001 F00		
A53810704	STRUT INSTL-FR 47/48	<input type="checkbox"/>
001 A00		
A53810705	BEAM ASSY-LWR	<input type="checkbox"/>
001 A00		
A53810706	CLIP INSTL FR40-L1	<input type="checkbox"/>
001 C00		
A53810707	STABILISER	<input type="checkbox"/>
001 C00		
A53810708	SIDE ASSY-FSLG,UPR	<input type="checkbox"/>
001 V00		
A53810709	STAB.MOUNT,	<input type="checkbox"/>
001 A00		
A53810710	STAB.MOUNT	<input type="checkbox"/>
001 B00		

Click here for "DRWG A53810702"

Result of the « search » for A538107*

Restart Download RFI Help

https://services.airbus.com - Engineering Drawings V5 - Windows Internet Explorer fourni par Sopra Group

AIRBUS

A53810702 - COMPONENTS ASSY-STRC

Picture Parts List Parts Usage History

Total number of sheets: 1

Drawing Number A53810702 (D53210000, D5321*)

Search Clear Advanced Search

Session Directory

- Tuning
- UnGhost current user
- RFI Control
- Download Control
- DNI
- DNI Control
- A53810702
- 001_NDL

Click "Parts List"

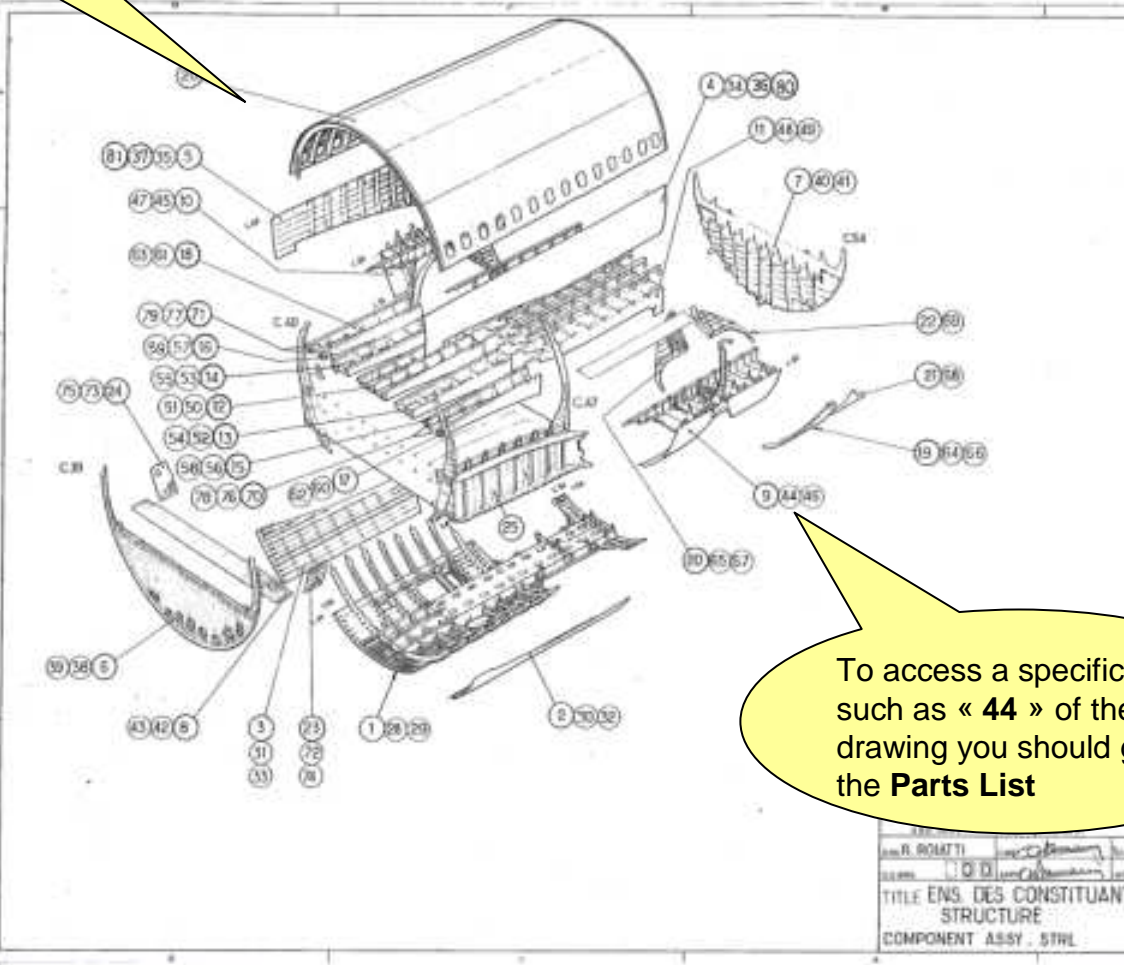

MODIFICATIONS:

DATE	REV. NO.	BY	REASON
	A	J. ADRIEU	
	C	P. ROBERT	
FROM	ECO	5127532	
	DRW	OMICRON	
FROM	ECO	10056 PM	
	DRW	MASMEH	
FROM	ECO	08918 FMI	
	DRW	FRECHOU	
FROM	ECO	09999 FMI	
	DRW	ALET	

Restart |< < > >| Print Download Full screen RFI Help

Terminal Internet

The selected drawing is displayed.
Note that a TIFF viewer is required

To access a specific item such as « 44 » of the drawing you should go to the **Parts List**

Mechanical Drawings

A53810702 - COMPONENTS ASSY-STRC

Item 44 is not in this page
Click the "next button"

Picture Parts List Parts Usage History

Total number of sheets: 1

1 / 6 71,5% Rechercher

Drawing Number: A53810702
(D53210000, D5321*)

Search Clear

Parts list associated
to drwg A53810702
is displayed

This Parts list
consists of 6
pages

Parts list is
highlighted

MOD.NO	008	007	006	005	004	003	002	001	000	Zone	Item	Part Number	Part Issue	Description	Hand	Protect	Id	In	Remark		
BEFORE/AFTER	QUANTITY PER ASSEMBLY													Material Specification							
N00	F2089999FMLA05			F00	F211194UFSRA10																
K00	S2089999FMLA06			L00	F2089999ST6AA17					M00	S210739KUSA02										
G00	F210056FMLAA71			H00	F210615CT1AA01					J00	F210615CT1AA03										
D00	S204012KUZAA08			E00	S206127832AA04					F00	F2089999ST6AA56										
A00	F203512ST6AF36			B00	F203512ST6AL29					C00	S203512ST6AA43										
MOD.NO: 008 007 006 005 004 003 002 001 000 BEFORE/AFTER: QUANTITY PER ASSEMBLY Zone: Item: Part Number: Part Issue: Description: Hand: Protect: Id: In: Remark:													PIC. N SHT. 001								
THIS DOCUMENT IS THE PROPERTY OF AIRBUS/ATLANTA. NO PART OF IT SHALL BE REPRODUCED OR TRANSMITTED WITHOUT THE EXPRESS WRITTEN AUTHORIZATION OF AIRBUS/ATLANTA AND ITS CONTENTS SHALL NOT BE DISCLOSED.												PROT. TREAT. CHART: A00710003 D.O.RESP. ATTC54		TITLE: AIRBUS COMPONENTS ASSY-STRC		DRAWING NO: 15 A53810702		SHEET S001		ISSUE F	
NOV 19/1999												Copyright AIRBUS				CONTD					

Restart Print Download Full screen RFI Help

Mechanical Drawings

Robin ANDERSON
AIRBUS
All MSN

A53810702 - COMPONENTS ASSY-STRC

Picture Parts List Parts Usage History

Total number of sheets: 1

Drawing Number: A53810702
(D53210000, D5321*)

Search Clear
Advanced Search

- Session Directory
- Tuning
- UnGhost current user
- RFI Control
- Download Control
- DNI
- DNI Control
- A53810702**
- 001_N00

3 / 6 125% Rechercher

Zone	Item	Part Number	Part Issue	Description Material Specification	Hand	Protect	Id	In	Rem
	51	A53411761000	P	ENS SUPPLIES FIXES		000			
	50	A53812286006	J	ENS POUVOIR VOILES					
	49	A53411757000	J	FITTING ASSY-FXD, 7/1					
	48	A53810711000	J	STRUCTURE ASSY		282			
	47	A53411756001	R	FITTING-FIXED					
	46	A53411756000	R	FITTING-FIXED					
	45	A53810708001	AF	PANEL-LATERAL		000			
	44	A53810708000	AF	PANEL-LATERAL		000			
	43	A53411755000	D	BRACKET ASSY					
1	42	A53810649001	J	ENSEMBLE PLANCHER					
1	41	A53411754000	Q	BRACKET ASSIES					
1	40	A53810800000	N	ENS FOND ETANCHE C54		000			

Click to access "item 44"

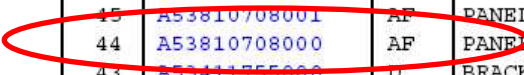

PROT. TREAT. CHART: A00710003 D.O.RESP. ATTC54

TITLE: AIRBUS COMPONENTS ASSY-STRC

DRAWING NO: 15 A53810702

SHEET S003

ISSUE P

Restart Print Download Full screen RFI Help

Mechanical Drawings

Robin ANDERSON
AIRBUS
All MSN

A53810708 - SIDE ASSY-FSLG,UPR

Picture Parts List Parts Usage History

Total number of sheets: 1

Drawing Number
(D53210000, D5321*)

Click "Picture" to display the associated drawing

Parts list associated with Drwg A53810708

- Session Directory
 - Tuning
 - UnGhost current user
 - RFI Control
 - Download Control
 - DNI
 - DNI Control
 - A53810702
 - 001_N00
 - A53810708**

MOD.NO	008	007	006	005	004	003	002	001	000	Zone	Item	Part Number	Part Issue	Description	Hand	Protect	Id	In	Remark	
												A53812183006	F	PANEL INSTL SIDE UPR						
												A53812183004	F	PANEL INSTL SIDE UPR						
												A53812183000	A	PANEL INSTL SIDE UPR						
												A53812175003	H	LATERAL INSTL-FRS3						
												A53812175001	H	MONTAGE C 53 PARTIE						
												A53812175002	H	LATERAL INSTL-FRS3						
												A53812175000	H	LATERAL INSTL-FRS3						
												A53812174003	G	LATERAL INSTL-FR 52	OH002					
												A53812174001	G	MONTAGE C53 PARTIE	OH000					
												A53812174002	G	LATERAL INSTL-FR 52						
												A53812174000	G	LATERAL INSTL-FR 52						
												A53812173003	F	LATERAL INSTL-FRS1	OH002					
												A53812173001	F	MONTAGE C51 PARTIE	OH000					
												A53812173002	F	LATERAL INSTL-FRS1						
												A53812173000	F	LATERAL INSTL-FRS1						
												A53812172005	F	LATERAL INSTL-FR49	OH004					
												A53812172001	F	LATERAL INSTL-FR49	OH000					
												A53812172004	F	LATERAL INSTL-FR49						
												A53812172000	F	LATERAL INSTL-FR49						
												A53812171003	F	LATERAL INSTL-FR 48	OH002					
												A53812171001	F	MONTAGE C48 PARTIE	OH000					
												A53812171002	F	LATERAL INSTL-FR 48						
												A53812171000	F	LATERAL INSTL-FR 48						
												A53812139203	F	DOUBLER-SKIN, FR 50	OH202					2
												A53812139201	D	DOUBLER-SKIN, FR 50	OH200					2
												A53812139202	F	DOUBLER-SKIN, FR 50						2
												A53812139200	D	DOUBLER-SKIN, FR 50						2
												A53812114001	E	FANEL-SIDE, AFT, LH						
												A53812114000	E	FANEL-SIDE, AFT, LH						
												A53812115002	F	FANEL-SIDE, AFT, RH						
												A53812115001	F	FANEL-SIDE, AFT, RH						
												A53812115000	F	FAN LAT AR DRT EQUIP						
												A53811018201	A	FANEL-SIDE, UFR.						2F
												A53810950203	K	FANEL-SIDE, UFR, G BAY						2
												A53810950201	J	FANEL-SIDE, UFR, G BAY						2
												A53811018200	A	FANEL-SIDE, UFR.						2F
												A53810950204	K	FANEL-SIDE, UFR, G BAY						2
												A53810950202	J	FANEL-SIDE, UFR, G BAY						2
												A53810950200	J	FANEL-SIDE, UFR, G BAY						2
												001	AF	FANEL-LATERAL						
												000	AF	FANEL-LATERAL						

MOD.NO 008 007 006 005 004 003 002 001 000 Zone Item Part Number Part Issue Description Hand Protect Id In Remark

ADD	P212433CPAA17	ABO	F211934ST6AA12	APD	P213012ST6AA01
ADQ	P212632ST6AA01	ABO	F211632ST6AA03	ACD	P212631ST6AA27
W00	P211693ST6AA01	Y00	F212149ST6AA05	Z00	S212149ST6AA12
T00	P210096FM1AA04	U00	F210054FM1AB14	V00	P210468FM1AA01
Q00	F209999ST6AJ07	R00	F209998ST6AA35	S00	P210053FM1AA09

THIS DOCUMENT IS THE PROPERTY OF AIRBUS. NO PART OF IT SHALL BE REPRODUCED OR TRANSMITTED WITHOUT THE EXPRESS WRITTEN AUTHORIZATION OF AIRBUS. D.O. RESS. ATTC26

PROT. TREAT. CHART: A00710003

TITLE: AIRBUS SIDE ASSY-FSLG, UPR

DRAWING NO: 15 A53810708

SHEET: 001

ISSUE: AF

SEP 28/2004 Copyright AIRBUS CONTD

https://services.airbus.com - Engineering Drawings V5 - Windows Internet Explorer fourni par Sopra Group

Mechanical Drawings

Robin ANDERSON
AIRBUS
All MSN

A53810708 - SIDE ASSY-FSLG,UPR

Picture Parts List Parts Usage History

Total number of sheets: 1

Drawing Number: A53810708 (D53210000, D5321*)

Search Clear

Session Directory

- Tuning
- UnGhost current user
- RF1 Control
- Download Control
- DNI
- DNI Control
- A53810702
- 001_NDD
- A53810708
- 001_VDD

Use zoom to enlarge bottom structure

The drawing A53810708 is shown

In the cascade the drawing displayed is always highlighted in red

Restart < > Print Download Full screen RF1 Help

https://services.airbus.com - Engineering Drawings V5 - Windows Internet Explorer fourni par Sopra Group

Mechanical Drawings

Robin ANDERSON
AIRBUS
All MSN

A53810708 - SIDE ASSY-FSLG,UPR

Picture Parts List Parts Usage History

Total number of sheets: 1

Click "Parts List"

Drawing Number: A53810708 (D53210000, D5321*)

Search Clear Advanced Search

Session Directory

- Tuning
- UnGhost current user
- RFI Control
- Download Control
- DNI
- DNI Control
- A53810702
- 001_N00
- A53810708
 - 001_V00

ON

47 20 28 50 C50 L29

We are interested in ITEM 20

Restart < < > > Print Download Full screen RFI Help

Internet

DE PLAN EST L
LOWE
IDENTIF L, AF
ADD
CUA
DIN
O.D. ORG
ENS
SII

Mechanical Drawings

Robin ANDERSON
AIRBUS
All MSN

A53810708 - SIDE ASSY-FSLG,UPR

Picture Parts List Parts Usage History

Total number of sheets: 1

Drawing Number: A53810708
(D53210000, D5321*)

Search Clear
Advanced Search

- Session Directory
 - Tuning
 - UnGhost current user
 - RFI Control
 - Download Control
 - DNI
 - DNI Control
 - A53810702
 - 001_N00
 - A53810708**
 - 001_V00

MOD.NO	BEFORE/AFTER	008	007	006	QUANTITY	Zone	Item	Part Number	Part Issue	Description	Material Specification	Hand	Protect	Id	In	Remark
SM1							1	21	AS3812674023	L	FANEL ASSY EDGINGS	OH022	282			C223
SM1							1	21	AS3812674021	K	FANELS ASSY-EDGINGS	OH020	282			C222
SM1							1	21	AS3812674019	J	FANEL ASSY EDGINGS	OH018	282			C221
SM2							1	21	AS3812674017	H	FANEL ASSY EDGINGS		282			
SM1							1	21	AS3812674015	G	FANEL ASSY EDGINGS		282			C218
SM1							1	21	AS3812674013	F	FANEL ASSY EDGINGS		282			C216
SM1							1	21	AS3812674011	E	FANEL ASSY EDGINGS		282			C215
BA1							1	21	AS3812674009	E	FANEL ASSY EDGINGS		282			C215
----							1	21	AS3812674007	E	FANEL ASSY EDGINGS		282			C220
BA1							1	21	AS3812674005	E	FANEL ASSY EDGINGS		282			C220
BB1							1	21	AS3812674003	B	FANEL ASSY EDGINGS		282			C210
----							1	21	AS3812674001	A	FANEL ASSY EDGINGS		282			C210
----							1	21	AS3812185015	P	FANEL ASSY-EDGINGS		282			C210
----							1	21	AS3812185013	P	FANEL ASSY-EDGINGS		282			
----							1	21	AS3812185011	J	FANEL ASSY-EDGINGS		282			
----							1	21	AS3812185009	H	FANEL ASSY-EDGINGS		282			
----							1	21	AS3812185007	G	FANEL ASSY-EDGINGS		282			
----							1	21	AS3812185005	G	FANEL ASSY-EDGINGS		282			
----							1	21	AS3812185003	G	FANEL ASSY-EDGINGS		282			
----							1	21	AS3812185001	G	FANEL ASSY-EDGINGS		282			
SM2						1	20	AS3812674024	J	FANEL ASSY EDGINGS		282				C224
SM1						1	20	AS3812674022	J	FANEL ASSY EDGINGS		282				C223
SM2						1	20	AS3812674020	K	FANELS ASSY-EDGINGS		282				C222
SM1						1	20	AS3812674018	J	FANEL ASSY EDGINGS		282				C221
SM2						1	20	AS3812674016	H	FANEL ASSY EDGINGS		282				
SM1						1	20	AS3812674014	H	FANEL ASSY EDGINGS		282				C218
SM1						1	20	AS3812674010	E	FANEL ASSY EDGINGS		282				C215
BA1						1	20	AS3812674008	E	FANEL ASSY EDGINGS		282				C215
----						1	20	AS3812674006	E	FANEL ASSY EDGINGS		282				C220
BA1						1	20	AS3812674004	E	FANEL ASSY EDGINGS		282				C220
BA1						1	20	AS3812674002	E	FANEL ASSY EDGINGS		282				C210
----						1	20	AS3812674000	A	FANEL ASSY EDGINGS		282				
----						1	20	AS3812185014	P	FANEL ASSY-EDGINGS		282				C210
----						1	20	AS3812185012	P	FANEL ASSY-EDGINGS		282				
----						1	20	AS3812185010	J	FANEL ASSY-EDGINGS		282				
----						1	20	AS3812185006	G	FANEL ASSY-EDGINGS		282				
----						1	20	AS3812185004	G	FANEL ASSY-EDGINGS		282				
----						1	20	AS3812185002	G	FANEL ASSY-EDGINGS		282				
----						1	20	AS3812185000		FANEL ASSY-EDGINGS		282				
----						1	19	AS3812183009	H	FANEL INSTL SIDE UPR		282				
----						1	19	AS3812183003	H	FANEL INSTL SIDE UPR	OH002	282				
----						1	18	AS3812183008	H	FANEL INSTL SIDE UPR		282				
----						1	18	AS3812183002	H	FANEL INSTL SIDE UPR		282				
----						1	17	AS3812183007	F	FANEL INSTL SIDE UPR		282				
----						1	17	AS3812183005	F	FANEL INSTL SIDE UPR	OH004	282				
----						1	17	AS3812183001	A	FANEL INSTL SIDE UPR	OH000	282				

Click "item 20"

Item column

THIS DOCUMENT IS THE PROPERTY OF AIRBUS. IT IS NOT TO BE REPRODUCED OR TRANSMITTED WITHOUT THE WRITTEN AUTHORIZATION OF AIRBUS INDUSTRIE AND ITS COMPANIES.

PROT. TREAT. CHART: A00710003
D.O.RESP. ATTC26

TITLE: AIRBUS
SIDE ASSY-FSLG, UPR

DRAWING NO: 15 A53810708

SHEET: S002

ISSUE: AF

SEP 28/2004 Copyright AIRBUS CONTD

Restart Print Download Full screen RFI Help

Mechanical Drawings

Robin ANDERSON
AIRBUS
All MSN

A53812674 - PANEL ASSY EDGINGS

Picture Parts List Parts Usage History

Total number of sheets: 1

Drawing Number: A53812674
(D53210000, D5321

Search Clear
Advanced Search

Click "picture" to display
"Panel Assy Edgings"

Parts list associated
with Item 20 « Panel
Assy Edgings »

MOD.NO	008	007	006	005	004	003	002	001	000	Zone	Item	Part Number	Part Issue	Description	Hand	Protect	id	In	Remark
												7	A53813325005	C	CROSS BEAM-FR 47A	CH004	282		
												7	A53813325003	B	CROSS BEAM-FR 47A	CH002	282		
												6	A53813325004	C	CROSS BEAM-FR 47A		282		
												6	A53813325002	B	CROSS BEAM-FR 47A		282		
												5	A53810676204	E	BEAM-LONGITUDINAL		000	2F	
												5	A53810676204	D	BEAM-LONGITUDINAL		000	2	
												4	A53810676207	E	BEAM-LONGITUDINAL	CH206	000	2F	
												4	A53810676205	D	BEAM-LONGITUDINAL	CH204	000	2	
												3	A53812170205	E	PANEL-EDGING_AFT		451	2	
												3	A53812170203	D	PANEL-EDGING_AFT		451	2	
												2	A53812170202	D	PANEL-EDGING_AFT		451	2	
												1	A53812734200	A	INSTRUMENT PANEL_RH		451	2F	
												0	A53812169200	D	INSTRUMENT PANEL_RH		451	2	
												1	A53812733200	D	INSTRUMENT PANEL_RH		451	2F	
												0	A53812169204	C	INSTRUMENT PANEL-LH		451	2	
												0	A53812169200	A	INSTRUMENT PANEL-LH		451	2	
												025	L	FANEL ASSY EDGINGS	CH024	282			
												024	L	FANEL ASSY EDGINGS		282			
												023	L	FANEL ASSY EDGINGS	CH022	282			
												022	L	FANEL ASSY EDGINGS		282			
												021	K	FANELS ASSY-EDGINGS	CH020	282			
												020	K	FANELS ASSY-EDGINGS		282			
												019	J	FANEL ASSY EDGINGS	CH018	282			
												018	J	FANEL ASSY EDGINGS		282			
												017	H	FANEL ASSY EDGING		282			
												016	H	FANEL ASSY EDGING		282			
												015	G	FANEL ASSY EDGING		282			
												014	G	FANEL ASSY EDGING		282			
												013	F	FANEL ASSY EDGING		282			
												011	E	FANEL ASSY EDGINGS					
												010	E	FANEL ASSY EDGINGS					
												009	E	FANEL ASSY EDGINGS					
												008	E	FANEL ASSY EDGINGS					
												007	E	FANEL ASSY EDGINGS					
												006	E	FANEL ASSY EDGINGS					
												005	E	FANEL ASSY EDGINGS					
												004	E	FANEL ASSY EDGINGS					
												003	B	FANEL ASSY EDGINGS					
												002	B	FANEL ASSY EDGINGS					
												001	A	FANEL ASSY EDGINGS		282			
												000	A	FANEL ASSY EDGINGS		282			

MOD.NO	008	007	006	005	004	003	002	001	000	Zone	Item	Part Number	Part Issue	Description	Hand	Protect	id	In	Remark		
BEFORE/AFTER	QUANTITY PER ASSEMBLY																				
K00	P212433CPRAA01	L00	P211924ST6AA19					J00	P212631ST6AA32	PIC. D											
G00	P212169ST6AA07	H00	S212169ST6AA14					F00	P210468FPM1AA03	SHT. 001											
D00	P210054FMLAB22	E00	P210096ST6AA02					C00	P210096FPM1AA03												
A00	P206508ST6AA04	B00	F209998ST6AA36																		
THIS DOCUMENT IS THE PROPERTY OF AIRBUS/SPAINALE. NO PART OF IT SHALL BE REPRODUCED OR TRANSMITTED WITHOUT THE EXPRESS WRITTEN AUTHORIZATION OF AIRBUS/SPAINALE AND ITS CONTENTS SHALL NOT BE DISCLOSED												PROT. TREAT. CHART: A00710003		TITLE: AIRBUS		DRAWING NO: 15 A53812674		SHEET 0001		ISSUE L	
FEB 05/2004												D.O.RESP. ATTC26		FANEL ASSY EDGINGS		Copyright AIRBUS		CONTD			

Restart Print Download Full screen RFI Help

https://services.airbus.com - Engineering Drawings V5 - Windows Internet Explorer fourni par Sopra Group

Mechanical Drawings

Robin ANDERSON
AIRBUS

A53812674

Use the viewer zoom to "Enlarge section CC"

○ Picture ○ Parts List ○ History

Total number of sheets: 1

Drwg A53812674 is displayed

Drawing Number: A53812674 (D53210000, D5321*)

Search Clear Advanced Search

Session Directory

- Tuning
- UnGhost current user
- RFI Control
- Download Control
- DNI
- DNI Control
- A53810702
 - 001_N00
- A53810708
 - 001_V00
- A53812674
 - 001_000

SECTION AA

SECTION BB

SECTION CC

SECTION DD

SECTION EE

SECTION FF

SECTION GG

SECTION HH

SECTION II

SECTION JJ

SECTION KK

SECTION LL

SECTION MM

SECTION NN

SECTION OO

SECTION PP

SECTION QQ

SECTION RR

SECTION SS

SECTION TT

SECTION UU

SECTION VV

SECTION WW

SECTION XX

SECTION YY

SECTION ZZ

SECTION AA

SECTION BB

SECTION CC

SECTION DD

SECTION EE

SECTION FF

SECTION GG

SECTION HH

SECTION II

SECTION JJ

SECTION KK

SECTION LL

SECTION MM

SECTION NN

SECTION OO

SECTION PP

SECTION QQ

SECTION RR

SECTION SS

SECTION TT

SECTION UU

SECTION VV

SECTION WW

SECTION XX

SECTION YY

SECTION ZZ

Restart |< < > >| Print Download Full screen RFI Help

Terminal Internet

Mechanical Drawings

Robin ANDERSON
AIRBUS
All MSN

A53812674 - PANEL ASSY EDGINGS

Picture

Parts List

Parts Usage

History

Total number of sheets: 1



Click on "Parts List" to access item 39

Drawing Number
(D53210000, D5321*)

- Session Directory
 - Tuning
 - UnGhost: current user
 - RFI Control
 - Download Control
 - DNI
 - DNI Control
 - A53810702
 - 001_N00
 - A53810708
 - 001_V00
 - A53812674
 - 001_000

SECTION CC

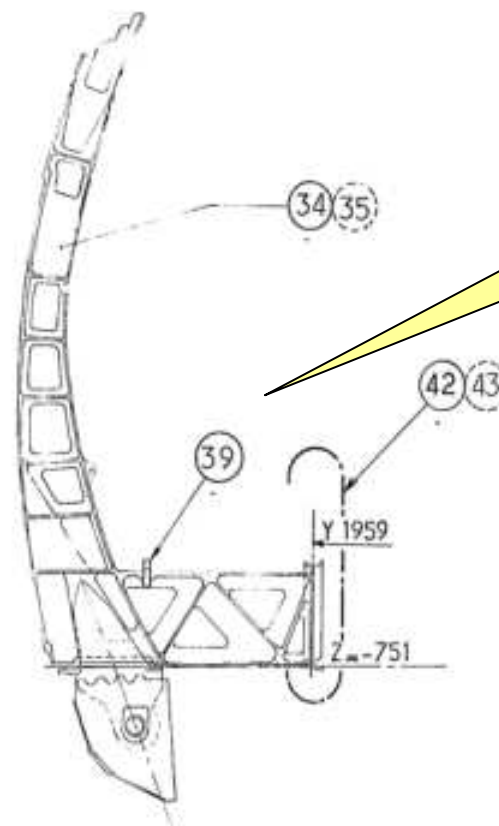

If you are Interested in item 39 go to « Parts List »

REF. PORTIQUE 5
LONG BEAM 5 DATUM
D ↑

LIGNE DU POINT 3
LINE OF POINT 3

Mechanical Drawings

Robin ANDERSON
AIRBUS
All MSN

A53812674 - PANEL ASSY EDGINGS

Picture

Parts List

Parts Usage

History

Total number of sheets: 1

Drawing Number: A53812674
(D53210000, D5321*)

Search Clear
Advanced Search

3 / 7 125% Rechercher

- Session Directory
 - Tuning
 - UnGhost current user
 - RFI Control
 - Download Control
 - DNI
 - DNI Control
 - A53810702
 - 001_N00
 - A53810708
 - 001_V00
 - A53812674
 - 001_D00

Click for "Item 39"

Item list to select your specific item

		A53812424008	C	FITTING INSTL-ATCH FR54		282			
		A53812424006	C	FITTING INSTL-ATCH FR53		282			
		A53813089000	A	MONT FER ATTACHE C50		282			
		A53812423003	B	JOINT-FR 50/BEAM 5	OH002	282			
		A53812423002	B	JOINT-FR 50/BEAM 5		282			
		A53833148204							
		A53823148205							
		A53812421005	C	FORKS INSTL-FR48/53		282			
		A53812421004	C	FORKS INSTL-FR48/53		282			
		A53812421000	C	FORKS INSTL-FR48/53		282			
		A53812186007	N	PANEL INSTL-EDGING	OH006	282			
		A53812186005	N	PANEL INSTL-EDGING	OH004	282			
		A53812186008	N	PANEL INSTL-EDGING		282			
		A53812186006	N	PANEL INSTL-EDGING		282			
		A53812186004	N	PANEL INSTL-EDGING		282			
		A53810891005	G	FITTING ASSY-FR 50	OH004				
		A53810891004	G	FERRURE AU C50 EQUIP					

Zone	Item	Part Number	Part Issue	Description Material Specification	Hand	Protect	Id	In	Remark
------	------	-------------	------------	---------------------------------------	------	---------	----	----	--------

Restart Print Download Full screen RFI Help

Mechanical Drawings

Robin ANDERSON
AIRBUS
All MSN

A53812421 - FORKS INSTL-FR48/53

Picture

Parts List

Parts Usage

History

Total number of sheets: 1

Click « Picture »
to display item 39
drawing

Drawing Number
(D53210000, D5321*)

Parts list contents
A53812421

- Session Directory
 - Tuning
 - UnGhost current user
 - RFI Control
 - Download Control
 - DNI
 - DNI Control
 - A53810702
 - 001_N00
 - A53810708
 - 001_V00
 - A53812674
 - 001_D00
 - A53812421**
 - 001_A00

MOD.NO BEFORE/AFTER	008	007	006	005	004	003	002	001	000	Zone	Item	Part Number	Part Issue	Description Material Specification	Hand	Protect	Id	In	Remark
				2	2		2			A-R	10	ASNA2020-48		RIVET TETE CYLINDRIQU					
											6	NSAS182-3		ECROU AUTO-FREINE					
											6	ASNA2029-3		ECROU HEXAGONAL					
											4	NSAS041VF3-21		VIS TETE CYLINDRIQU					
											4	ASNA2004V3-21		VIS TETE CYLINDRIQU					
											2	A53832245202							
				1	1		1				0	A53812376200	A	CHAPE DE LIAISON		010		2	
												005	C	FORKS INSTL-FR48/53					282
												004	C	FORKS INSTL-FR48/53					282
												003	C	FORKS INSTL-FR48/53					282
												002	C	FORKS INSTL-FR48/53					282
												000	C	FORKS INSTL-FR48/53					282

A00 P2035128T6AML9												B00 S2035128T6AB65				C00 P20472128T6AA63				PIC. A											
																SHT. 001															
THIS DOCUMENT IS THE PROPERTY OF AIRBUS/ATLANTIA. NO PART OF IT SHALL BE REPRODUCED OR TRANSMITTED WITHOUT THE EXPRESS PRIOR WRITTEN AUTHORIZATION OF AIRBUS/ATLANTIA AND ITS CONTENTS SHALL NOT BE DISCLOSED.												PROT. TREAT. CHART: A00710003 D.O.RESP. ATVIA2				TITLE: AIRBUS FORKS INSTL-FR48/53				DRAWING NO: 15 A53812421				SHEET S001				ISSUE C			
JAN 06/1984																Copyright AIRBUS								END							

-
-
-
-
-
-

https://services.airbus.com - Engineering Drawings V5 - Windows Internet Explorer fourni par Sopra Group

Mechanical Drawings

Robin ANDERSON
AIRBUS
All MSN

A53812421 - FORKS INSTL-FR48/53

Parts List Parts Usage History

Total number of sheets: 1

Drawing Number: A53812421
(D53210000, D5321*)

Search Clear

Advanced Search

Session Directory

- Tuning
- UnGhost current user
- RFI Control
- Download Control
- DNI
- DNI Control
- A53810702
 - 001_N00
- A53810708
 - 001_V00
- A53812674
 - 001_D00
- A53812421
 - 001_A00

SECTION AA

SECTION BB

MODIFICATIONS

REVISION: A3 2012 016 ANZ
By: J. Garcia

10

2

18

100

0 20 40 60 80 100
MILLIMETRES

DATE: 01/01/2011	AUTHOR: J. Garcia	APPR: J. Garcia
REVISION: A3 2012 016 ANZ	REVISION: A3 2012 016 ANZ	REVISION: A3 2012 016 ANZ
DESIGNER: J. Garcia	DESIGNER: J. Garcia	DESIGNER: J. Garcia
CHECKER: J. Garcia	CHECKER: J. Garcia	CHECKER: J. Garcia
DATE: 01/01/2011	DATE: 01/01/2011	DATE: 01/01/2011
TITLE: MONTAGE CHAPES C 48 A C 53 FORKS INSTALLATION FR 48 TO FR 53		
15 A 538 12421 A		

Restart |< < > >| Print Download Full screen RFI Help

Terminal Internet

Final drawing at the cascade bottom is displayed

Please note that you navigate from « top » to « bottom » in the drawings cascade

Click anywhere on this page to continue tutorial

Engineering Drawings

–Tutorial part 2

- Bottom - Up navigation using Parts Usage
- Important functions such as:
 - DNI
 - RFI
 - Print
 - Download

NEXT

https://services.airbus.com - Engineering Drawings V5 - Windows Internet Explorer fourni par Sopra Group

Mechanical Drawings

Robin ANDERSON
AIRBUS
All MSN

A53812421 - FORKS INSTL-FR48/53

Picture Parts List Parts Usage History

Total number of sheets: 1

Drawing Number: A53812421 (D53210000, D5321*)

Search Clear Advanced

From this drawing you want to access the « Next Higher Assembly »

Notice that the drawing displayed on screen is highlighted in the cascade

Click "Parts Usage"

SECTION AA

REF. C 48, 49, 51, 52, 53
FR 48, 49, 51, 52, 53, 54/04

10

FR 48 T/N FR 48 T/N
FR 48 T/N FR 48 T/N

Y 2462

Z = -605

SECTION BB

18

Y 2462

SECTION CC

18

Y 2462

SCALE

0 10 20 30 40 50 60 70 80 90 100
MILLIMETRES

DATE: 01/01/01	REVISION: 01	DESIGNER: J. Garcia
APPROVED: J. Garcia	DATE: 01/01/01	SCALE: 1:1
TITLE: MONTAGE CHAPES C 48 A C 53 FORKS INSTALLATION FR 48 TO FR 53		
PART NUMBER: 15 A 538 12421		REV: 01

Restart < < > > Print Download Full screen RFI Help

Terminal Internet

https://services.airbus.com - Engineering Drawings: V5 - Windows Internet Explorer fourni par Sopra Group

Mechanical Drawings

Robyn ANDERSON
AIRBUS
All MSN

A53812421 - FORKS INSTL-FR48/53

Picture Parts List Parts Usage History

Total number of sheets: 1

Drawing Number

Search Advanced Search

Session Directory

- Tuning
- UnGhost current user
- RFI Control
- Download Control
- DNI
- DNI Control
- A53812421
 - 001_A00
- A53812376
 - 001_A00
- A53910588
 - 001_C00

SECTION AA

SECTION BB

MODIFICATIONS

TECHNICAL SPECIFICATIONS

REVISIONS

OK Cancel

Restart < > Print Download Full screen RFI Help

Terminé Internet

Please Select :

An Aircraft Family: A300/A300-600/A310

A MSN (optional): 0794 ?

After selecting family and MSN (optional) Click "OK"

A pop up requires that you confirm the aircraft family . Inserting a MSN is optional

TITLE MONTAGE CHAPES
C 48 A C 53
FORKS INSTALLATION
FR 48 TO FR 53

15 A 538 12421 A

Mechanical Drawings

Robin ANDERSON
AIRBUS

A300/A300-600/A310 MSN : 0794

A53812421 - FORKS INSTL-FR48/53

Picture

Parts List

Parts Usage

History

Total number of sheets: 1

Drawing Number:
(D53210000, D5321*)

Parts Usage associated with drawing A53812421 is shown

- Session D
- Tuning
- UnGhost cur
- RFI Control
- Download Control
- DNI
- DNI Control
- A53812421**
 - 001_A00
- A53812376
 - 001_A00
- A53810588
 - 001_C00

Part Nbr	Iss	Description Mod. Number Next Higher Assy	Qty	Aircraft Type/Family: Wide Body Registration Number: N680FE Version: FDX01	MSN: 0794 Standard: ST6 RANK: 0030
000	C00	FORKS INSTL-FR48/53			
		A53812674010	5	FDX01 0030 0030	
		A53812674011	5	FDX01 0030 0030	
004	C00	FORKS INSTL-FR48/53			
		A53812674006	1	FDX01 0030 0030	
		A53812674010	1	FDX01 0030 0030	
		A53812674022	1	FDX01 0030 0030	
005	C00	FORKS INSTL-FR48/53			
		A5381267400	1	FDX01 0030 0030	
		A538126740	1	FDX01 0030 0030	

Select link to go to NHA (Next Higher Assembly)

Mechanical Drawings

Robin ANDERSON
AIRBUS

A300/A300-600/A310 MSN : 0794

A53812674 - PANEL ASSY EDGINGS

Picture

Parts List

Parts Usage

History

Total number of sheets: 1

Drawing Number:
(D53210000, D5321*)

- Session Directory
 - Tuning
 - UnGhost current user
 - RFI Control
 - Download Control
 - DNI
 - DNI Control
 - A53812674**
 - 001_D00
 - A53812421
 - 001_A00
 - A53812376
 - 001_A00
 - A53810588
 - 001_C00

Select "Picture"
to see the
NHA

Note that you
are going up
through the
drawing
cascade

1 / 1 71,5% Rechercher

Part Nbr	Qty	Aircraft Type/Family: Wide Body Registration Number: N680FE Version: FDX01	MSN: 0794 Standard: ST6 BANK: 0030
010	08000	1	FDX01 0030 0030
011	08001	1	FDX01 0030 0030

AIRBUS INDUSTRIE
31700 ELAGNAC FRANCE, BP No33

PARTS USAGE

Date : AUG 25/2009

This document must not be copied without permission of the owners

Copyright AIRBUS

Drawing Number
15 A53812674

Page
U001

END

https://services.airbus.com - Engineering Drawings V5 - Windows Internet Explorer fourni par Sopra Group

Mechanical Drawings

Robin ANDERSON
AIRBUS
A300/A300-600/A310 MSN : 0794

A53812674 - PANEL ASSY EDGINGS

Picture Parts List Parts Usage History

Total number of sheets: 1

Drawing Number: A53812674 (D53210000, D5321*)

Search Clear Advanced Search

Session Directory

- Tuning
- UnGhost current us
- RFI Control
- Download Control
- DNI
- DNI Control
- A53812674
 - 001_D00
- A53812421
 - 001_A00
- A53812376
 - 001_A00
- A53810588
 - 001_C00

SECTION A1 SECTION B0 SECTION C0

Click anywhere on this page to continue tutorial

The Next Higher Assembly assembly is shown

Print Download Full screen RFI Help

Internet

The image is a screenshot of a web-based engineering drawing viewer. At the top, the browser address bar shows 'https://services.airbus.com - Engineering Drawings V5 - Windows Internet Explorer fourni par Sopra Group'. The main header area contains the title 'A53812674 - PANEL ASSY EDGINGS' and navigation options: 'Picture' (selected), 'Parts List', 'Parts Usage', and 'History'. Below this, it states 'Total number of sheets: 1'. On the left side, there is a sidebar with a search bar containing 'A53812674' and a 'Session Directory' tree. The tree shows a hierarchy of folders and files, with 'A53812674' expanded to show '001_D00'. A red arrow points to '001_D00'. The main drawing area displays a technical drawing of a panel assembly with several sections labeled 'SECTION A1', 'SECTION B0', and 'SECTION C0'. A large callout bubble on the left says 'Please note that you navigated from « bottom » to « top » in the drawings cascade'. Another callout bubble on the right says 'Click anywhere on this page to continue tutorial'. A third callout bubble at the bottom says 'The Next Higher Assembly assembly is shown'. At the bottom of the drawing area, there are buttons for 'Print', 'Download', 'Full screen', 'RFI', and 'Help'. The bottom status bar shows 'Terminal' and 'Internet'.

https://services.airbus.com - Engineering Drawings V5 - Windows Internet Explorer fourni par Sopra Group

Mechanical Drawings

Robin ANDERSON
AIRBUS
A300/A300-600/A310 MSN : 0794

A53812674 - PANEL ASSY EDGINGS

Picture Parts List Parts Usage History

Total number of sheets: 1

Search Advanced

Session Directory

- Tuning
- UnGhost current user
- RFI Control
- Download Control
- DNI
- DNI Control
- A53812674
 - 001_C00
 - A53812421
 - 001_A00
 - A53812376
 - 001_A00
 - A53810588
 - 001_C00

SECTION A-A SECTION B-B SECTION C-C

Click "RFI"

Restart |< < > >| Print Download Full screen RFI Help

Internet

For additional information or specific request concerning a drawing use the RFI button

Click "RFI"

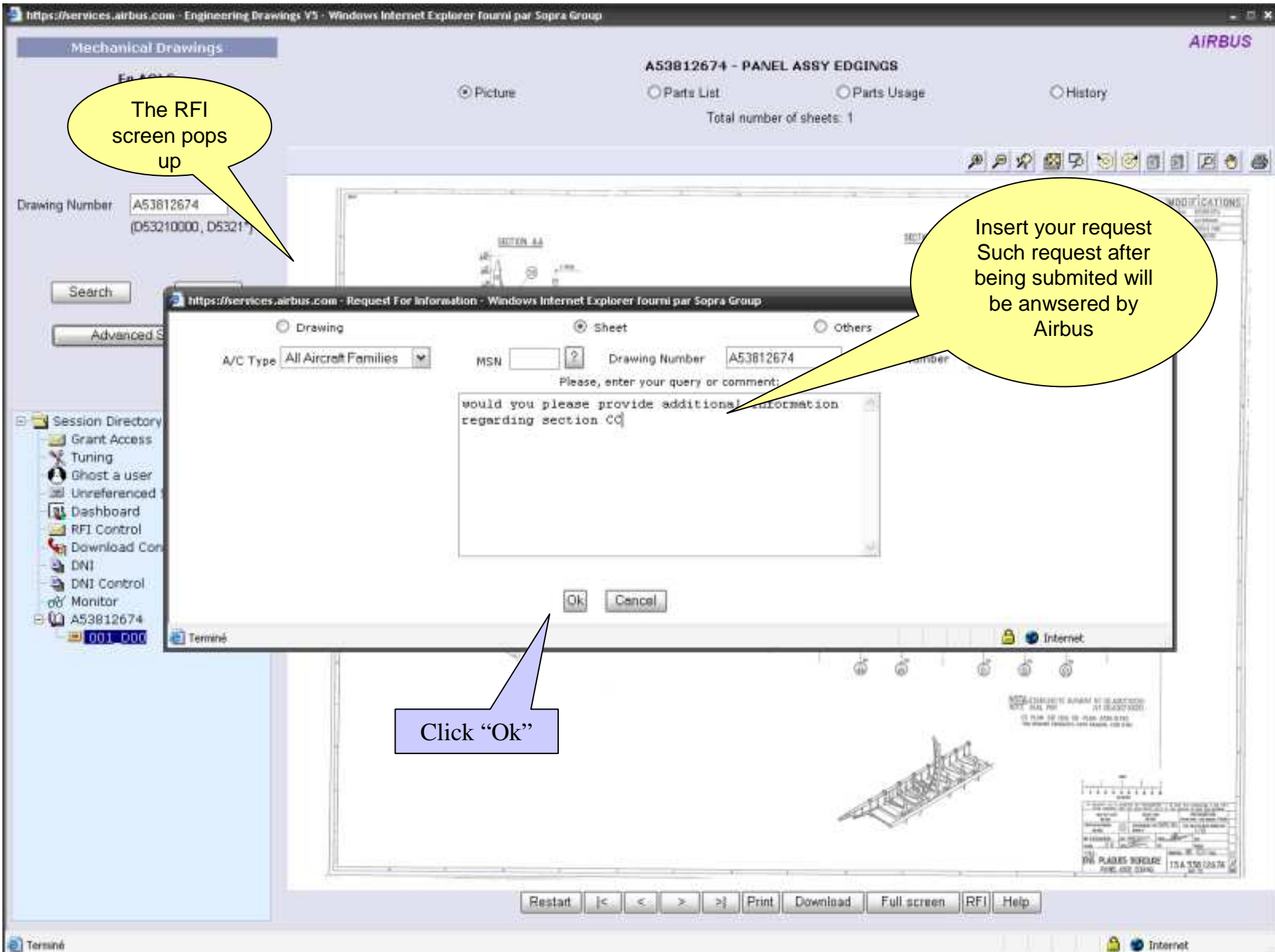

The RFI screen pops up

Insert your request Such request after being submitted will be answered by Airbus

Click "Ok"

Any drawing or
Parts List can be
visualized in « Full
Screen »

Picture Parts List Parts Usage History

Total number of sheets: 1



Drawing Number A53812674
(D63210000, D6321*)

Search Clear
Advanced Search

- Session Directory
- Grant Access
- Tuning
- Ghost a user
- Unreferenced Sheet Report
- Dashboard
- RFI Control
- Download Control
- DNI
- DNI Control
- Monitor
- A53812674
- 001-000

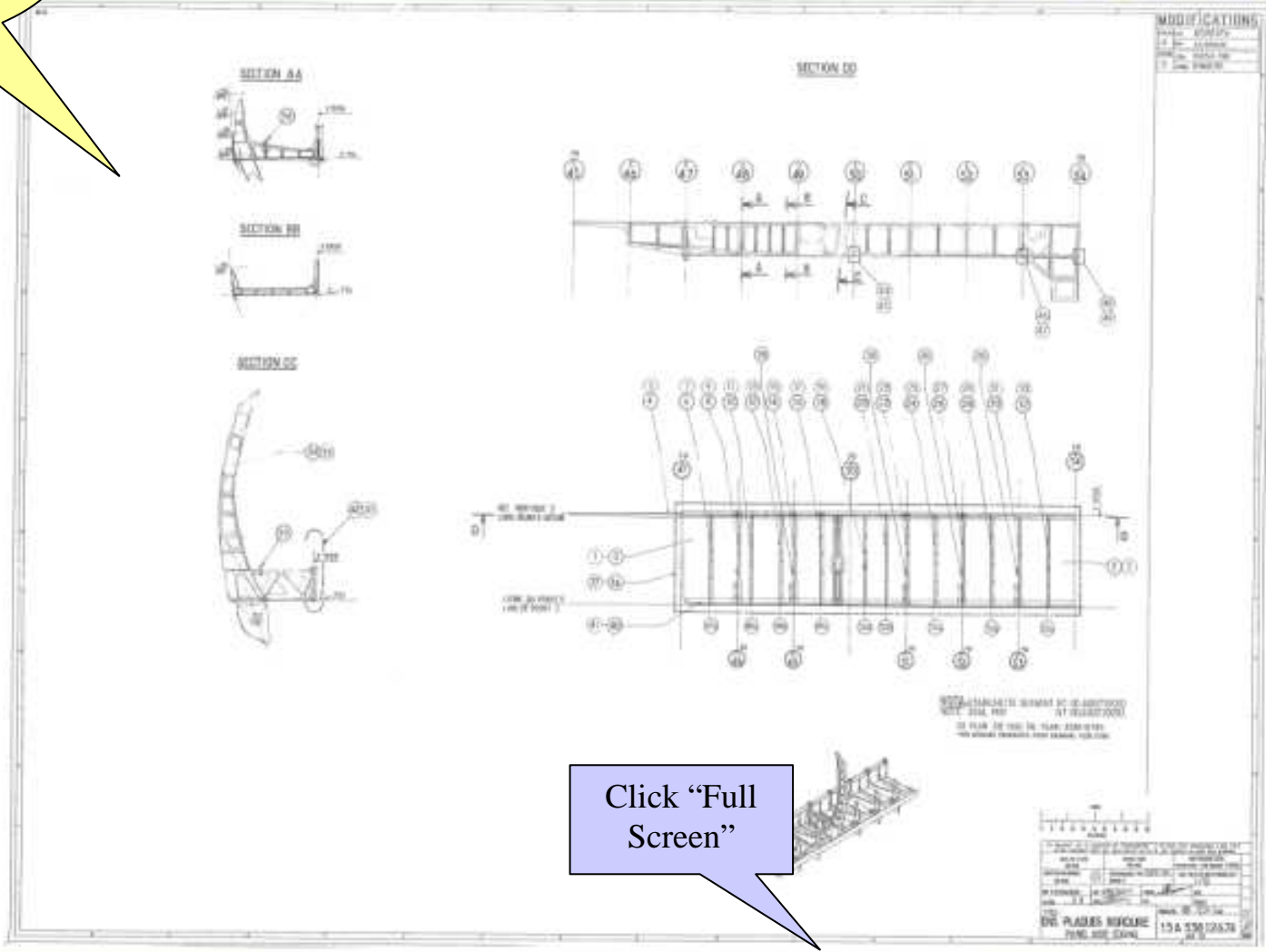

MODIFICATIONS

NO	DESCRIPTION	DATE	BY
1
2
3

Click "Full
Screen"

Restart |< < > >| Print Download Full screen RFI Help



MODIFICATIONS

A	01	01	01
B	01	01	01
C	01	01	01

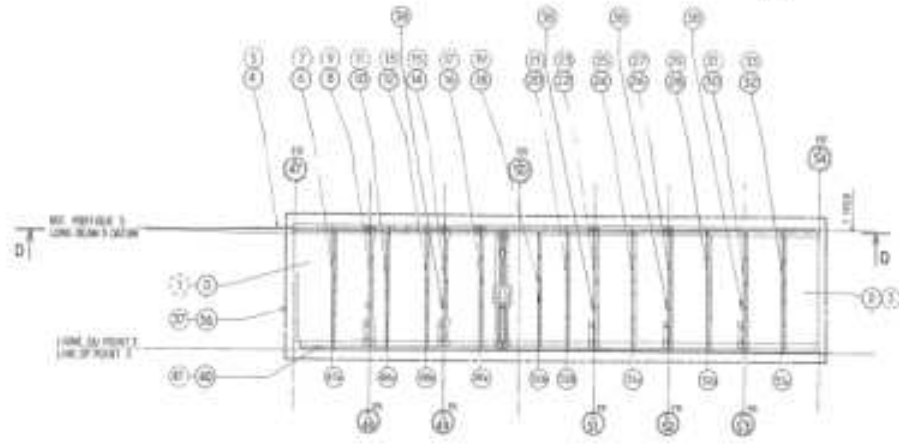
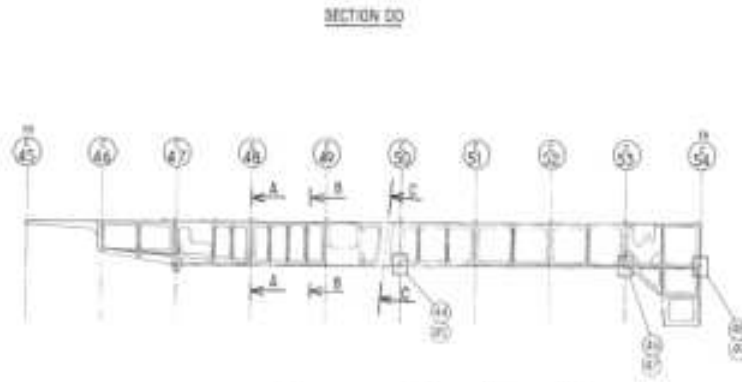
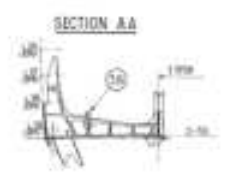

NOTA: L'ASSEMBLAGE SUIVANT NE DOIT PAS ÊTRE
NOTÉ: SEAL, PFI
ET PLAIN: 02, 03, 04, 05, 06, 07, 08, 09, 10, 11, 12, 13, 14, 15, 16, 17, 18, 19, 20, 21, 22, 23, 24, 25, 26, 27, 28, 29, 30, 31, 32, 33, 34, 35, 36, 37, 38, 39, 40, 41, 42, 43, 44, 45, 46, 47, 48, 49, 50, 51, 52, 53, 54, 55, 56, 57, 58, 59, 60, 61, 62, 63, 64, 65, 66, 67, 68, 69, 70, 71, 72, 73, 74, 75, 76, 77, 78, 79, 80, 81, 82, 83, 84, 85, 86, 87, 88, 89, 90, 91, 92, 93, 94, 95, 96, 97, 98, 99, 100



BIS PLIQUES BORDURE	
PERMEABILITE COEF	
15 A 538 126.74	

The previous drawing is displayed in full screen

Click "Back" to revert to standard screen

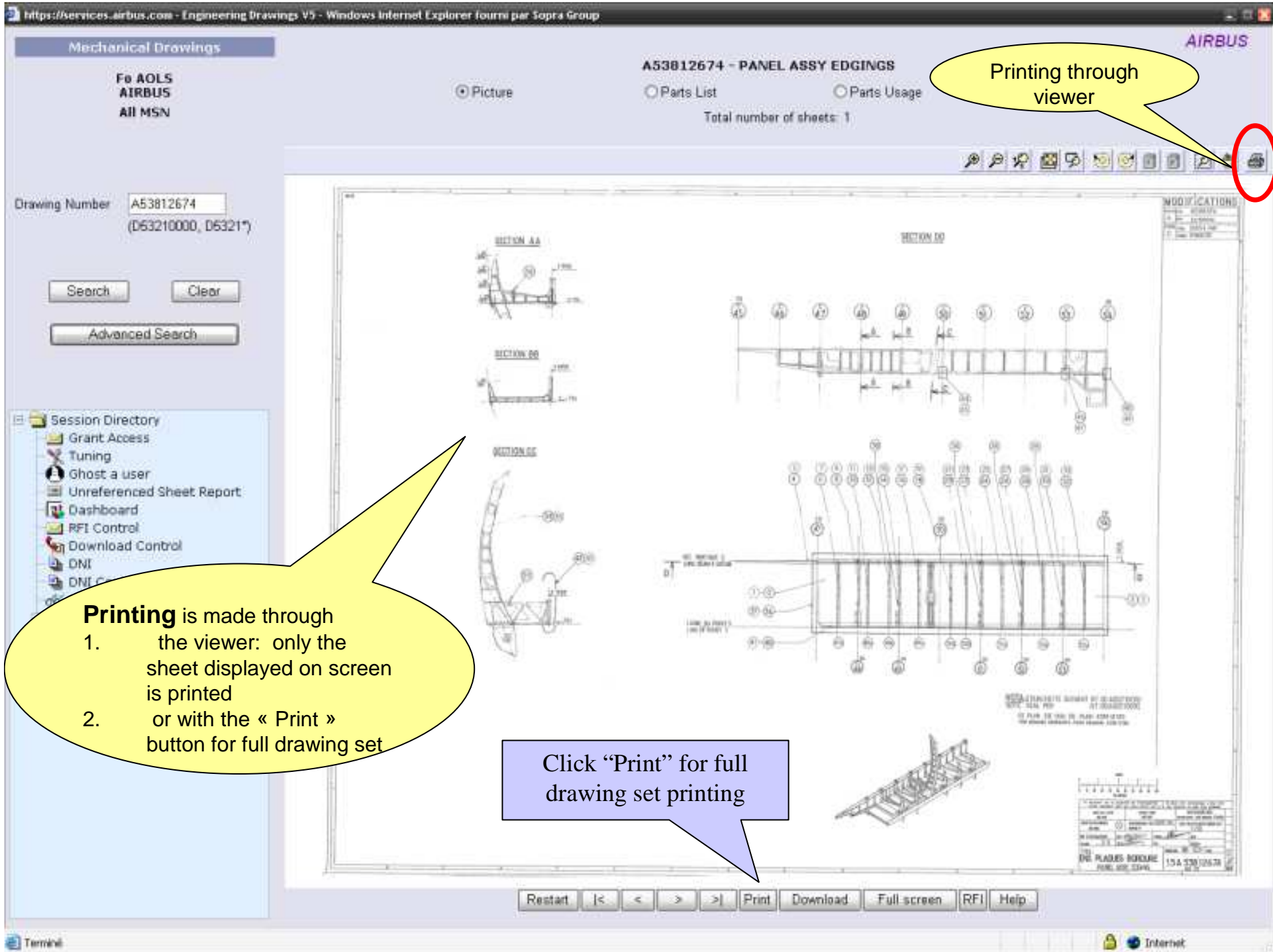

Printing through viewer



Printing is made through

1. the viewer: only the sheet displayed on screen is printed
2. or with the « Print » button for full drawing set

Click "Print" for full drawing set printing

Restart |< < > >| Print Download Full screen RFI Help

https://services.airbus.com - Engineering Drawings V5 - Windows Internet Explorer fourni par Sopra Group

Mechanical Drawings

Robin ANDERSON
AIRBUS
A300/A300-600/A310 MSN : 0794

A53812674 - PANEL ASSY EDGINGS

Picture Parts List Parts Usage History

Total number of sheets: 1

Drawing Number: A53812674
(D53210000, ...)

Search Clear
Advanced Search

Session Directory
Tuning
UnGhost current user
RFI Control
Download Control
DNI
DNI Control
A53812674
001_000
A53812421
001_A00
A53812376
001_A00
A53810588
001_C00

Select document(s)

Pictures
Sheet Number (optional):
Enter sheet numbers and/or ranges separated by ";" (for example: 001;003-007)

Parts List
 Parts usage

Please select:
An Aircraft Family: A300/A300-600/A310
A MSN (optional):

Ok Cancel

Terminé Internet

Restart |< < > >| Print Download Full screen RFI Help

Internet

The printing screen appears

Selection of the full set or part of the set is done here

Click "OK" for printing selected items

https://services.airbus.com - Engineering Drawings V5 - Windows Internet Explorer forami par Sopra Group

Mechanical Drawings

Robin ANDERSON
AIRBUS
A300/A300-600/A310 MSN : 0794

A53812674 - PANEL ASSY EDGINGS

Picture Parts List Parts Usage History

Total number of sheets: 1

Drawing Number: A53812674 (053210000, 05321*)

Search Clear Advanced Search

Session Directory

- Tuning
- UnGhost current user
- RFI Control
- Download Control
- DNI
- DNI Control
- A53812674
 - 001_000
 - A53812421
 - 001_A00
 - A53812376
 - 001_A00
 - A53810588
 - 001_C00

Document(s) generated

Documents ready for download:

Drawing Pictures:	2009/25/08 DrawingPictures	239 KB
Part List:	2009/25/08 PartList	100 KB
Part Usage:	2009/25/08 PartUsage	12 KB

Download all these documents

Click on link for one part of set or button to download all set

Once files downloaded you can print document(s) on your personal printer

Restart |< < > >| Print Download Full screen RFI Help

Terminé Internet

https://services.airbus.com - Engineering Drawings V5 - Windows Internet Explorer fourni par Sopra Group

Mechanical Drawings

Fo AOLS AIRBUS

A53812674 - PANEL ASSY EDGINGS

Picture Parts List Parts Usage History

Total number of sheets: 1

Search Clear Advanced Search

Session Directory
Grant Access
Tuning
Ghost a user
Unreferenced Sheet Report
Dashboard
RFI Control
Download Control
DNI
DNI Control
Monitor
A53812674
001-000

SECTION AA SECTION DD SECTION DD SECTION DD

Click "Download"

Restart |< < > >| Print Download Full screen RFI Help

Terminal Internet

If numerous drawing sets are required the « Download » Function is most appropriated

Click "Download"

https://services.airbus.com - Engineering Drawings V5 - Windows Internet Explorer fourni par Sopra Group

Mechanical Drawings

Robin A...

A300/A300-6...

A53812674 - PANEL ASSY EDGINGS

Picture Parts List Parts Usage History

Total number of sheets: 1

Drawing Number: A53812674 (D53210000, D5321*)

Search Clear Advanced Search

Session Directory

- Tuning
- UnGhost current user
- RFI Control
- Download Control
- DNI
- DNI Control
- A53812674
 - 001_C00
- A53812421
 - 001_A00
- A53812376
 - 001_A00
- A53810588
 - 001_C00

Download Drawing A53812674...

Select document(s):

- Pictures
- Sheet Number (optional):
- Enter sheet numbers and/or ranges separated by ";" (for example: 001;003-007)
- Parts List
- Parts Usage
- Please Select:
- An Aircraft Family: A300/A300-600/A310
- An MSN (optional):

A data package is computed in five minutes in average
To get your data click on the 'Advanced Search' the on Status for 'Download'

Ok Cancel

Terminé Internet

Click "OK"

The download screen appears

Selection of the full set or part of the set is done here

Restart |< < > >| Print Download Full screen RFI Help

Terminé Internet

https://services.airbus.com - Engineering Drawings V5 - Windows Internet Explorer fornito per Sopra Group

Mechanical Drawings

Robin ANDERSON
AIRBUS
A300/A300-600/A310 MSN : 0794

A53B12674 - PANEL ASSY EDGINGS

Picture Parts List Parts Usage History

Total number of sheets: 1

Drawing Number: A53B12674 (053210000, 05321*)

Search Clear Advanced Search

Session Directory

- Tuning
- UnGhost current user
- RFI Control
- Download Control
- DNI
- DNI Control
- A53B12674
 - 001_000
 - A53B12421
 - 001_A00
 - A53B12376
 - 001_A00
 - A53B10588
 - 001_C00

Request 1841400 created

Click "Close"

A reference is provided when server received the request. Package is in progress

Restart |< < > >| Print Download Full screen RFI Help

Terminé Internet

Mechanical Drawings

Fa AOLS
AIRBUS
All MSN

A53812674 - PANEL ASSY EDGINGS

Picture

Parts List

Parts Usage

History

Total number of sheets: 1



Drawing Number: A53812674
(D53210000, D5321*)

Search Clear

Advanced Search

Click "Advance Search"

- Session Directory
- Grant Access
- Tuning
- Ghost a user
- Unreferenced S
- Dashboard
- RFI Control
- Download Control
- DNI
- DNI Control
- Monitor
- A53812674
- 001-000

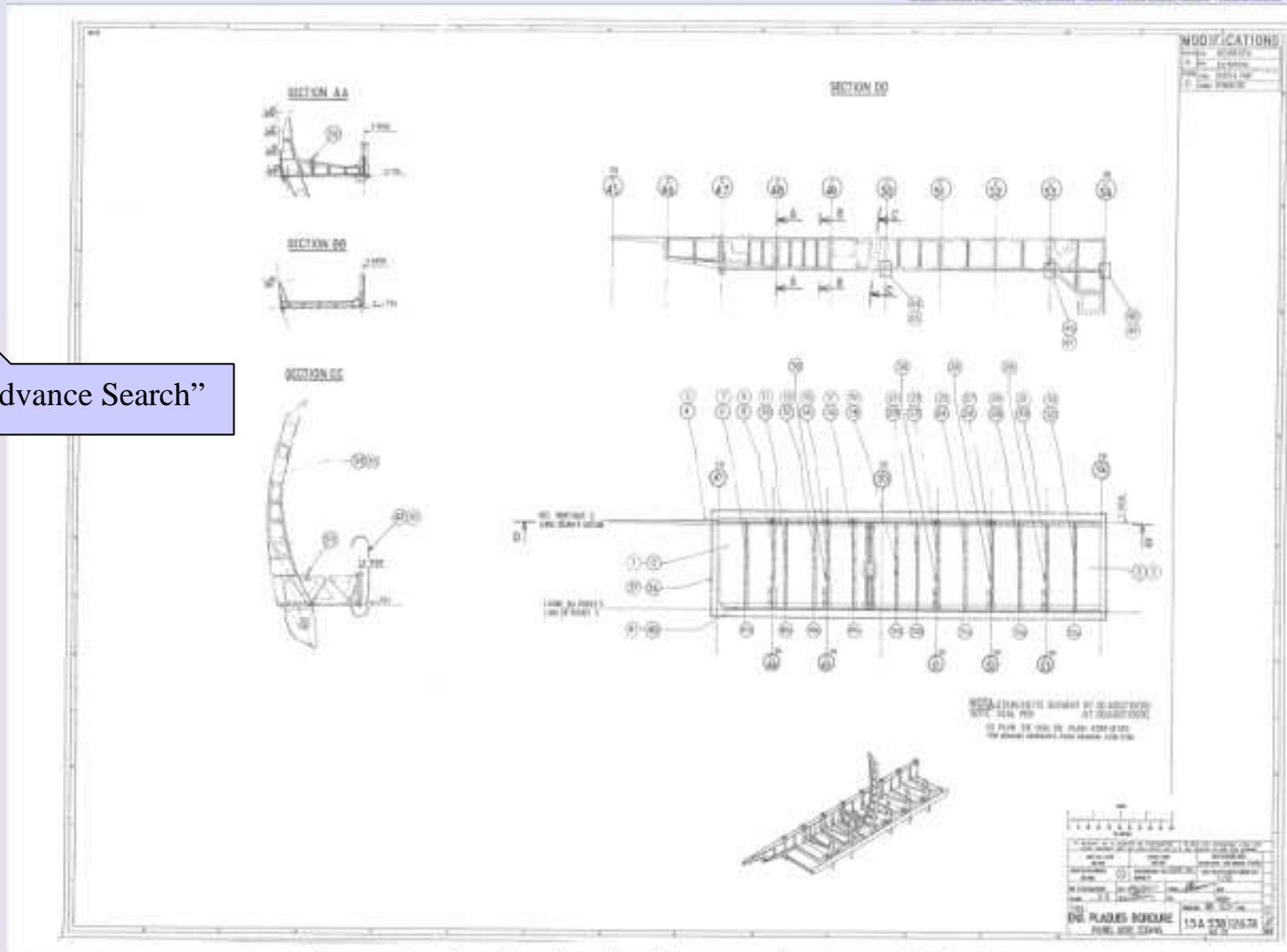

Restart |< < > >| Print Download Full screen RFI Help

https://services.airbus.com - Engineering Drawings V5 - Windows Internet Explorer fourni par Sopra Group

Mechanical Drawings

Robin ANDERSON
AIRBUS
A300/A300-600/A310 MSN : 0794

Download status : Mechanical

Data package 1841400 requested by Robin ANDERSON (AIB)

Drawing Number : A53812674
Title :
Tail Number :
Status for: RFI Download DNI

Reference	Data Package	Submitted on :	Available
A53812674	Sheet 001_D00	25-AUG-09	Extracted
A53812674	Parts List		Extracted
A53812674	Parts Usage	Wide Body	Extracted

Click **DOWNLOAD** to get your download status

Your requested data package is ready for download

Click « Download » and after don't forget to « Delete » Package

Click here to end Tutorial

Restart RFI Help

Terminé Internet

Engineering Drawings

THANK YOU